

### 7.3mm Cannulated Cancellous Screw, 16mm Thread, Stainless Steel

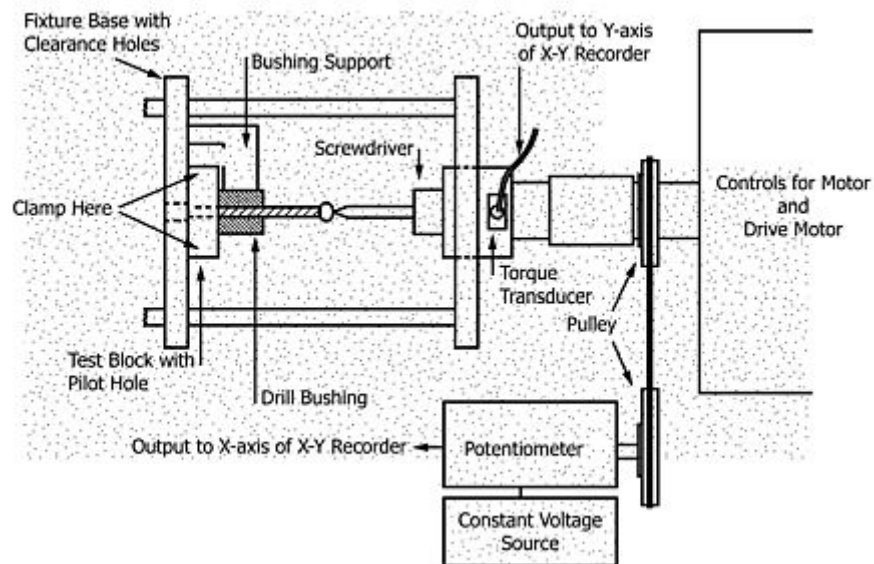

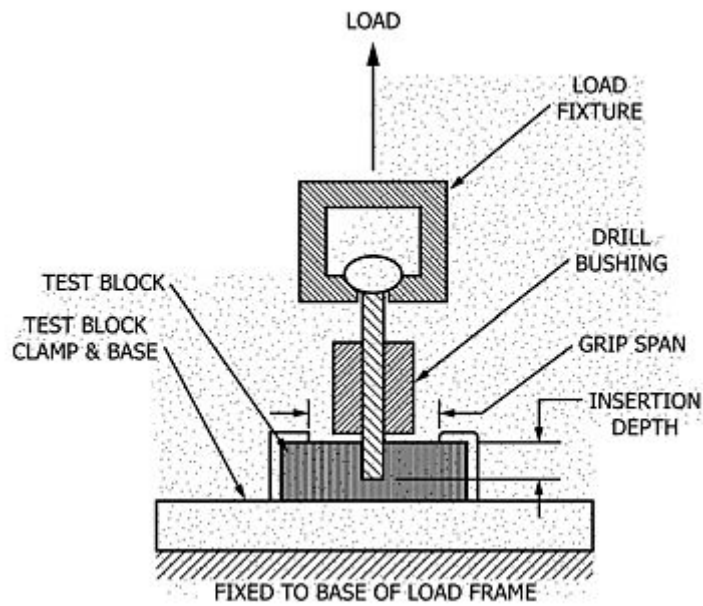
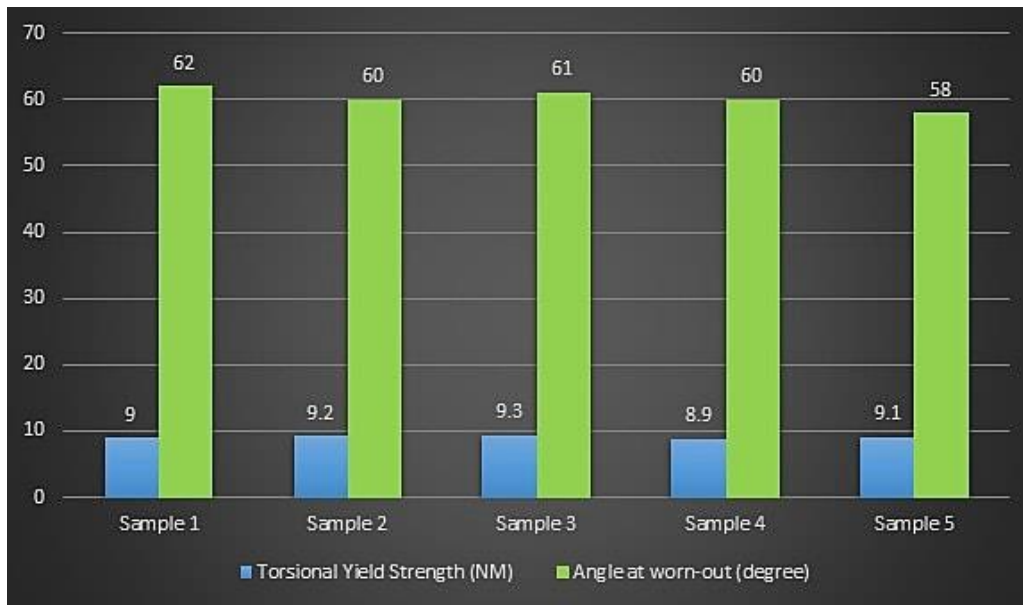

The Metallic Bone screws Manufactured by M/S Auxein Medical Pvt. Ltd. tested as per the test method described in ASTM F543-17 for torsional strength.