

Surgical Technique

Tarsus Nailing System

Guidelines

This publication sets forth detailed recommended procedures for using Auxein Medical devices and instruments.

It offers guidance that needs to be heeded. However, with any such technical guide, each surgeon must consider the unique needs of each patient and make appropriate adjustments when and as required.

A workshop training under DAIS Academy by Auxein will provide assistance prior to first surgery. It is vital to know that all non-sterile devices must be cleaned and sterilized before use.

Moreover, multi-component instruments must be disassembled for cleaning. The surgeon must discuss all relevant risks, including the finite lifetime of the device, with the patient, when necessary.

Please NOTE that all the bone screws referenced in this document here are not approved for screw attachment or fixation in the areas not mentioned in this publication.

Warning:

This description is not sufficient for immediate application of the instrumentation. Instruction by a surgeon experienced in handling this instrumentation is highly recommended.



about us

Auxein Medical is an integrated, research based, orthopaedic Implants & instruments manufacturing company, producing a wide range of quality, affordable generic implants, trusted by healthcare professionals and patients across geographies. It is the Company's constant endeavor to provide a wide basket of generic and our innovator products that exceed the highest expectations of customers in term of quality and safety. The company has world-class manufacturing unit established in india and serves customers in over 75 countries worldwide.

Our Achievements



INTRODUCTION

The Tarsus Nail is indicated to facilitate tibiotalocalcaneal arthrodesis to treat:

- Severe foot /ankle deformity
- Arthritis
- Instability and skeletal defects after tumor resection; these include, but are not limited to, neuro-osteoarthropathy
- Avascular necrosis of the talus
- Failed joint replacement or failed ankle fusion
- Distal tibial fracture

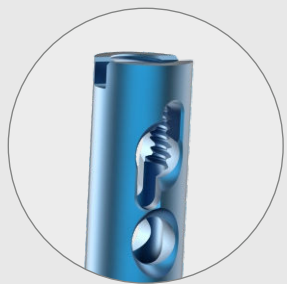

Left

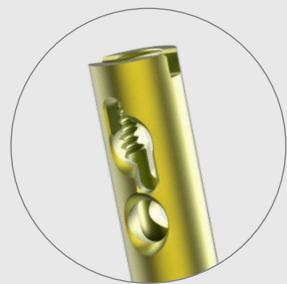

Right



Position patient

Position the patient on a radiolucent operating table.

Position the C-arm to allow visualization of the tibiotalar and subtalar joints in both the AP and ML views.

Please note that the procedure can be done with the patient prone, or in lateral decubitus or supine positions according to surgeon's preference. However, the following technique with the patient in prone position is recommended.

Determine nail length and diameter

Measure length

- Position the C-arm for a lateral view of the distal tibia and subtalar joint. With long forceps, hold the **(7-066-01)** radiographic ruler parallel to the tibia.

Adjust the ruler until the distal end is at the desired nail insertion depth. Mark the skin at that site on the lateral side.

- Move the image intensifier proximally with the ruler positioned on the distal skin mark. An image of the ruler can be used to choose the optimum nail length.

Measure diameter

- Position the C-arm for a lateral view of the tibia with the distal tibia centered on the screen.

Hold the ruler over the tibia so that the diameter gauge is centered over the narrowest part of the medullary canal that will contain the nail.

Read the diameter measurement on the circular indicator to estimate the canal size.

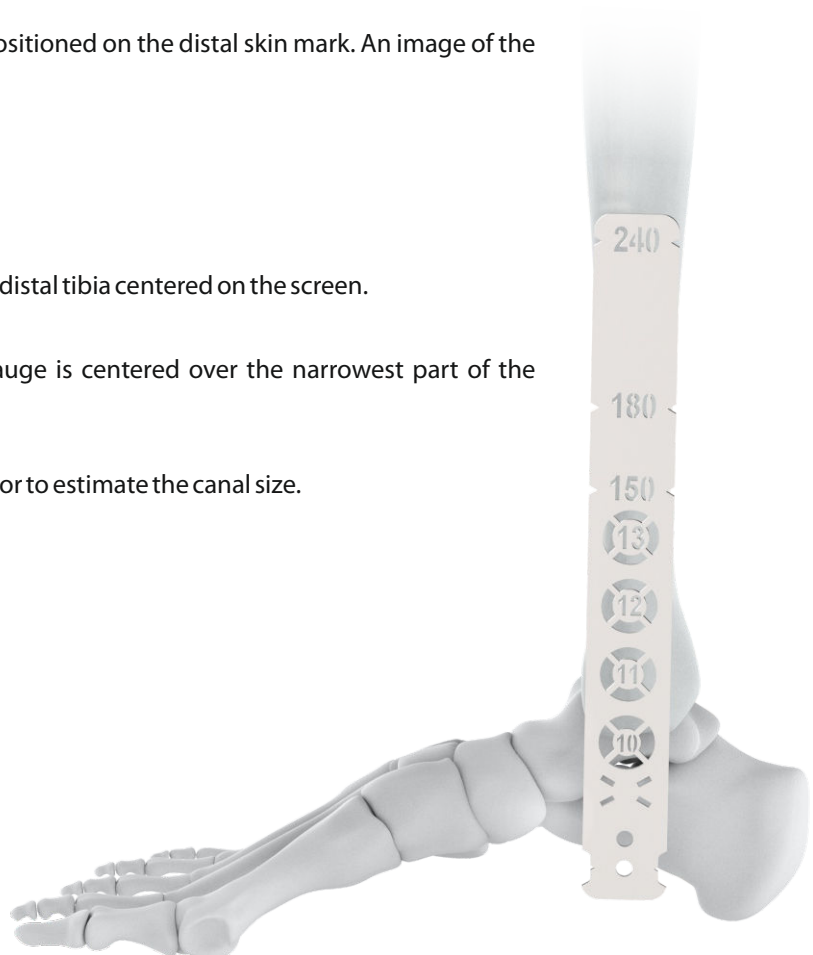

Skin Incision:

1. Perform fibula osteotomy

Create an incision laterally over the fibula. Curve the approach anteriorly, just distal to the tip of the fibula. Dissection to the bone is directed anteriorly. Using a sagittal saw, create an osteotomy 10 cm from the distal tip of the fibula. Resect approximately 1 cm of bone proximal to the first cut, creating a gap. This bone segment can be utilized as bone graft.

Incise the anterior soft tissue including anterior tibiofibular, calcaneofibular and talofibular ligaments.

Take care to preserve the posterior soft tissue. By maintaining a blood supply to this bone, it can be used later as a biological plate on the lateral distal tibia.

Reflect the distal segment posteriorly hinging on the posterior ligaments.

Using a sagittal saw, remove the medial fibular cortex and articular surface. Maintain the bone to be utilized as bone graft.

2. Determine entry point

- On a lateral fluoroscopic image, identify and mark the center of the tibial canal with the help of the 3.2 mm guide wire held adjacent to the leg.

Insert guide wire through calcaneus and talus

(7-066-35) 13.0 mm/3.2 mm trocar into the **(7-066-34)** 13.0 mm protection sleeve. Insert this assembly through the incision to the bone. Hold the protection sleeve firmly and insert the **(7-066-40)** 3.2 mm threaded guide wire through the trocar. Under power, insert the guide wire through the center of the lateral column of the calcaneus, angling medially toward the center of the Talus dome.

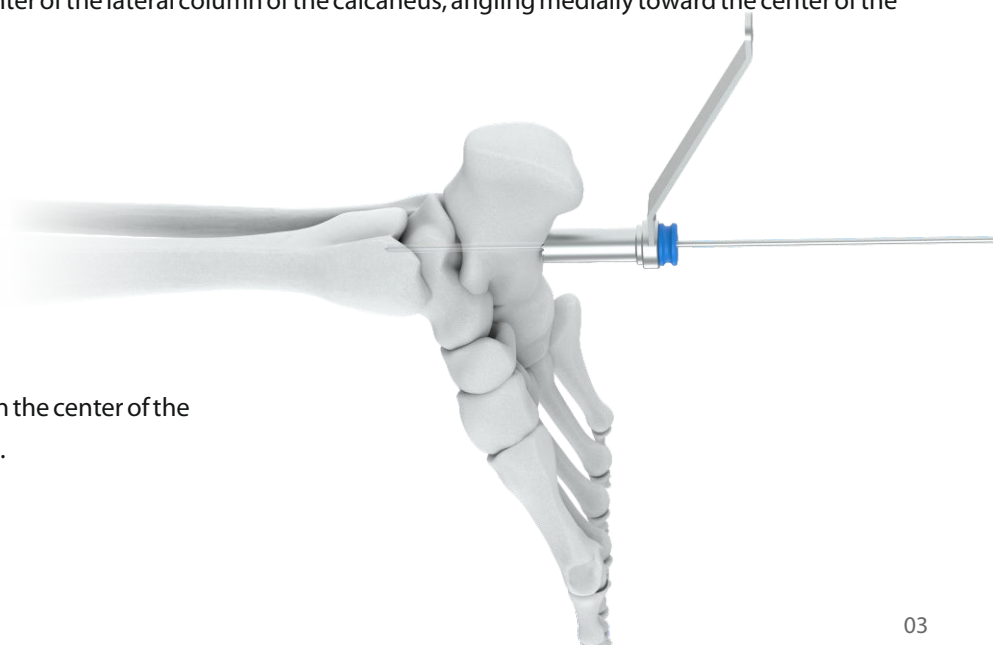

- Direct the guide wire so it exits the talus in the center of the articular surface in both AP and ML views.

3. Opening the canal:

Remove the (7-066-35) trocar from the protection sleeve.

Place the (7-066-33) 13.0 mm cannulated entry reamer over the guide wire and through the protection sleeve to the bone. Drill through the calcaneus and talus until the opening drill exits the talus. Take care to avoid the tibial plafond.

Remove the 3.2 mm guide wire.

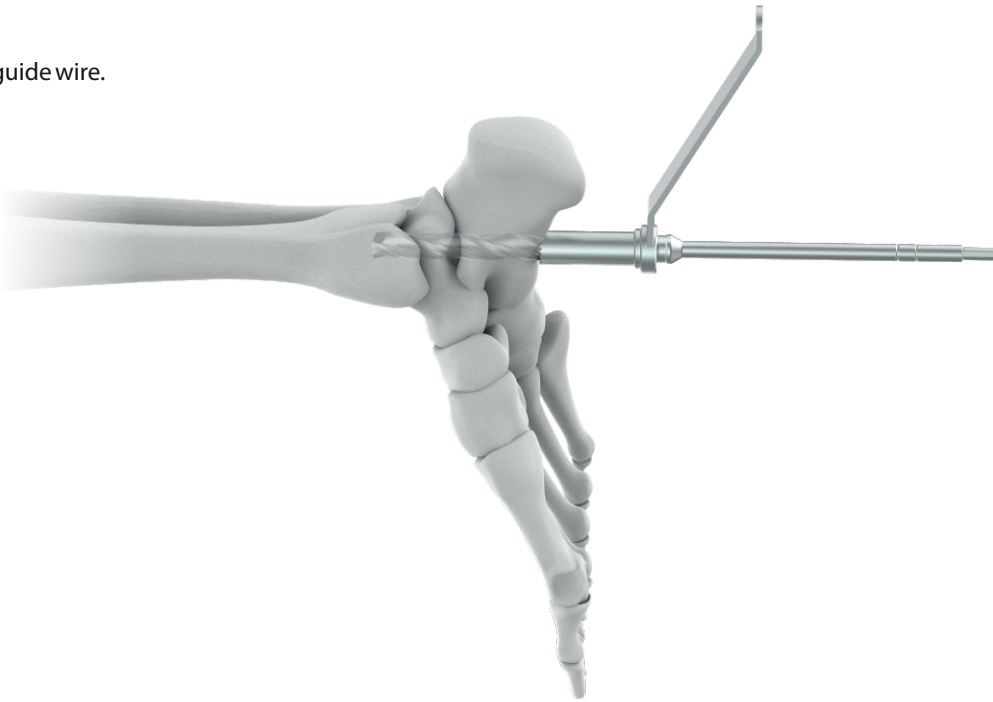

4. Opening for guide wire entry

- Insert the (7-066-06) Ø5.0 mm Three Fluted drill bit through the canal created in the calcaneus and talus. Under imaging, Center the drill point under the tibial canal in both the AP and lateral planes. Use the drill to create a defect in the subchondral bone to allow passage of the ball tip reaming rod.



Reaming (Recommended)

5. Reaming (recommended)

Insert reaming rod Insert the reaming rod through the calcaneus and talus into the medullary canal of the tibia.

Ream

Starting with the 8.0 mm reaming head, ream in 0.5 mm increments to a diameter of 1 mm larger than the nail diameter. Advance the reamer with steady, moderate pressure and do not force it. Partially retract the reamer often to clear debris from the medullary canal.

Recommended Set

7-006 Flexible Reamer Set for IM Nails

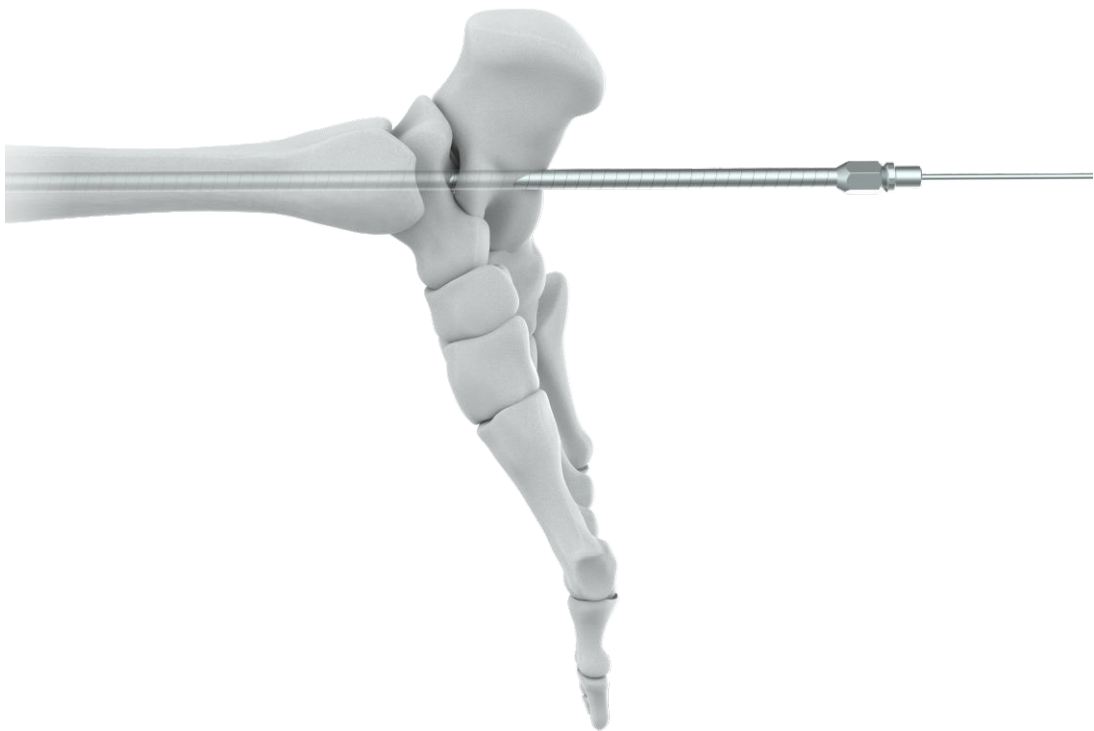

Inserting the Nail

1. Assemble insertion instruments

Orient the nail so that it matches the nail diagram on the **(7-066-05)** insertion handle.

Match the tang on the insertion handle to the notch in the Tarsus nail. Place the **(7-066-30)** Cannulated Nail Connecting screw into the Insertion handle and thread it into the nail, using the **(7-066-39)** Cannulated Shaft, Hex 8mm.

The aligned tangs will interface properly only if the nail bend is oriented toward the flat portion of the insertion handle.



2. Insert nail

Verify reduction and alignment under image intensification.

Using a twisting motion, insert the nail over the reaming rod as far as possible. Use the insertion assembly to manipulate the nail across the joints. Insert the nail until its instrument end is flush with the calcaneal opening.

If needed, use light, controlled (7-066-11) Sliding hammer blows to seat the nail. Thread the (7-066-04) Driving Cap onto the insertion handle. Thread the (7-066-36) Hammer Guide into the driving cap, use light controlled (7-066-11) Sliding hammer blows to seat the nail.

Confirm that the nail has aligned the foot anatomically.

Once the nail is seated, remove the driving cap.



Optional:

If needed lock the head of the slide/fixed hammer in place, using the (7-066-32) 4.5 mm pin wrench to tighten the nut onto the threads below the hammer head. Strike the driving cap directly.

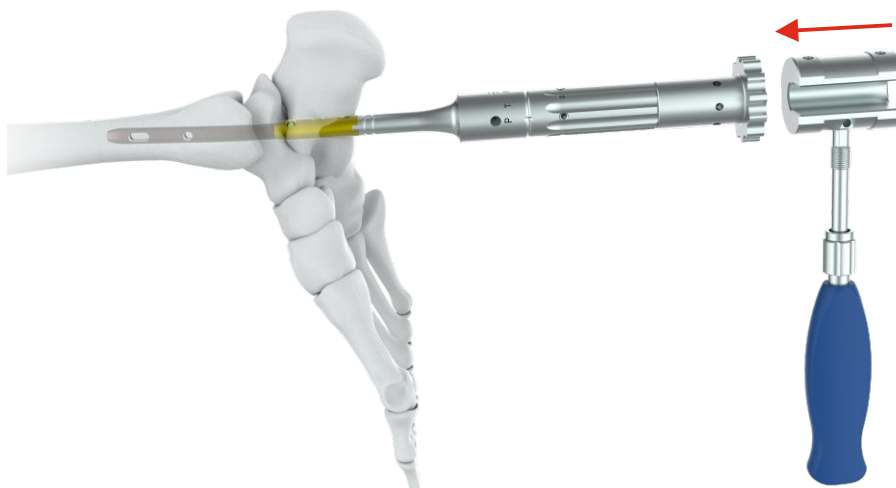

Distal Locking With Spiral Blade

Notes:

- Distal locking first is recommended, to allow later compression across joints being fused.
- Distal locking options include a spiral blade with or without a 6.0 mm locking screw, or two 6.0 mm locking screws.
- Optimal talus screw placement will dictate nail depth and rotation. If this is determined to be a critical screw, the distal locking procedure may be started with this screw. However, this method limits positioning of calcaneus locking elements.
- Screw orientation can be estimated by placing a 3.2 mm guide wire through the appropriate holes of the insertion handle. With the foot in weight-bearing position, the guide wire should be aligned with the medial column through the talus hole, or the fourth ray when placed through the posterior to anterior hole.

1. Confirm nail and spiral blade position

Partially thread the alignment pin into the aiming arm.

Attach the **(7-066-07)** Aiming Arm to the insertion handle. Orient the aiming arm so the letter "P", for posterior, can be seen on the insertion handle. Tighten the **(7-066-03)** Threaded Alignment Pin.

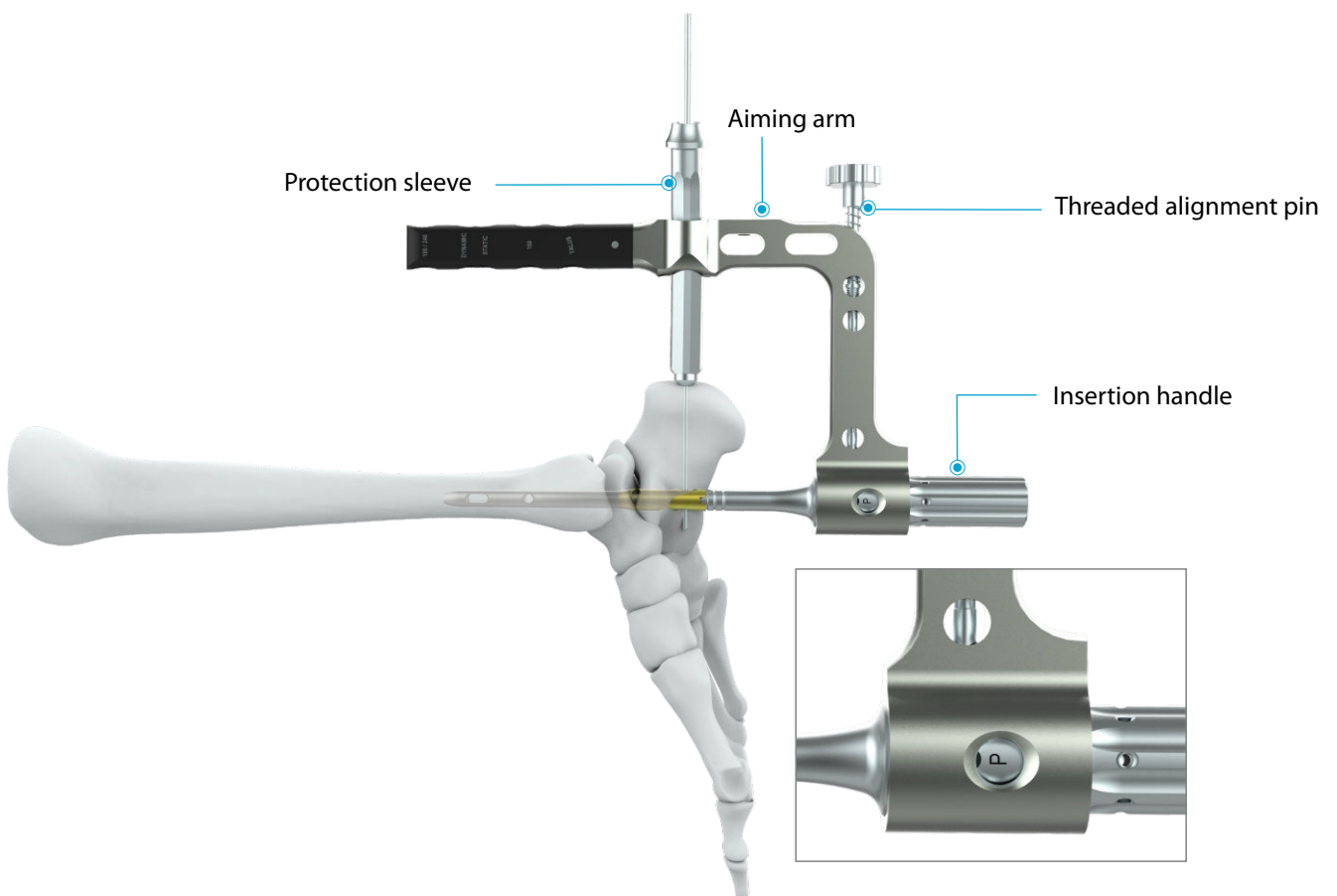

1. Confirm nail and spiral blade position (continued) Assemble the **(7-066-21)** 15.0/13.0 Protection Sleeve and wire guide and insert the sleeve assembly into the aiming arm. Create a posterior incision and advance the sleeve to the bone.

- Insert a **(7-066-40)** 3.2mm Threaded Guide Wire through the wire guide into the calcaneus until the tip is flush with the anterior cortex. Confirm wire position radiographically. This position will determine the final position of the spiral blade.

2. Measure for spiral blade length

Remove the wire guide. Place the spiral blade **(7-066-23)** Measuring Device over the guide wire and advance it to the bone. Read the graduation of the measuring device at the end of the guide wire. This measurement is the length of the spiral blade.

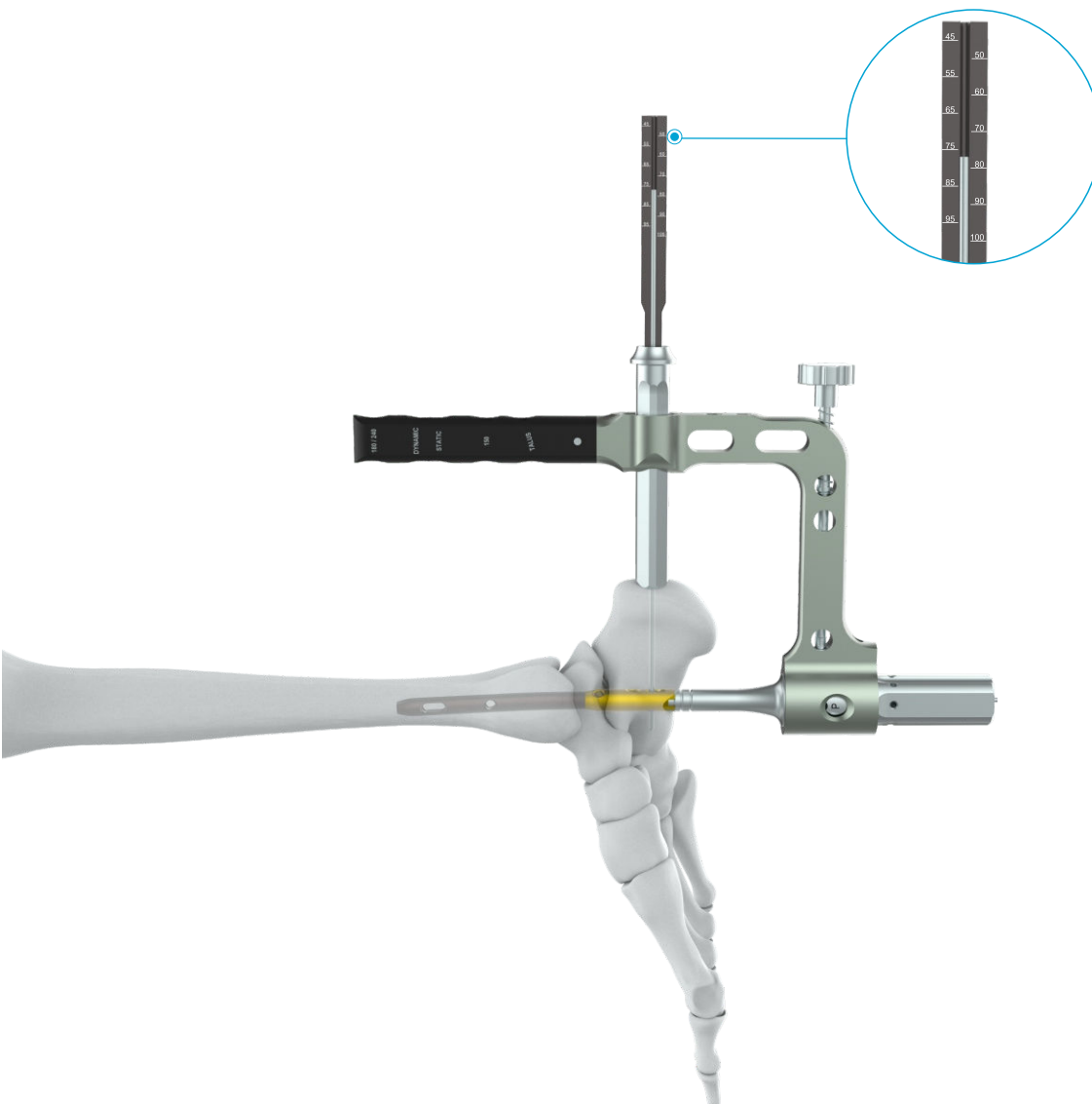

3. Open posterior cortex

Make an incision to split the Achilles tendon before inserting the spiral blade, to prevent damage to the soft tissue and risk of necrosis.

Insert the cannulated drill bit over the guide wire and through the protection sleeve to perforate the posterior cortex.

An automatic stop prevents the drill bit from penetrating too far.

Remove the drill bit and protection sleeve, leaving the guide wire in place.

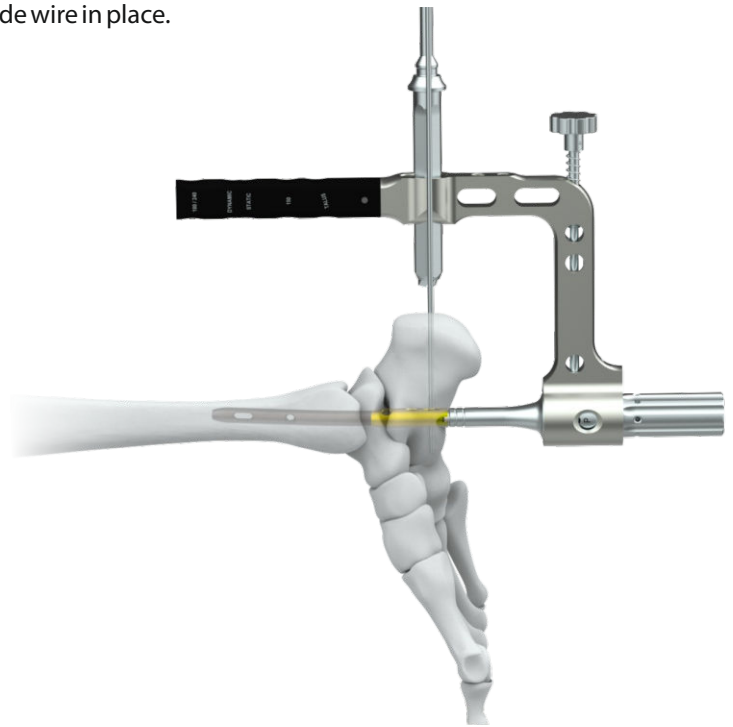

4. Attach adapter

Attach the (7-066-08) Aiming Arm Adapter.

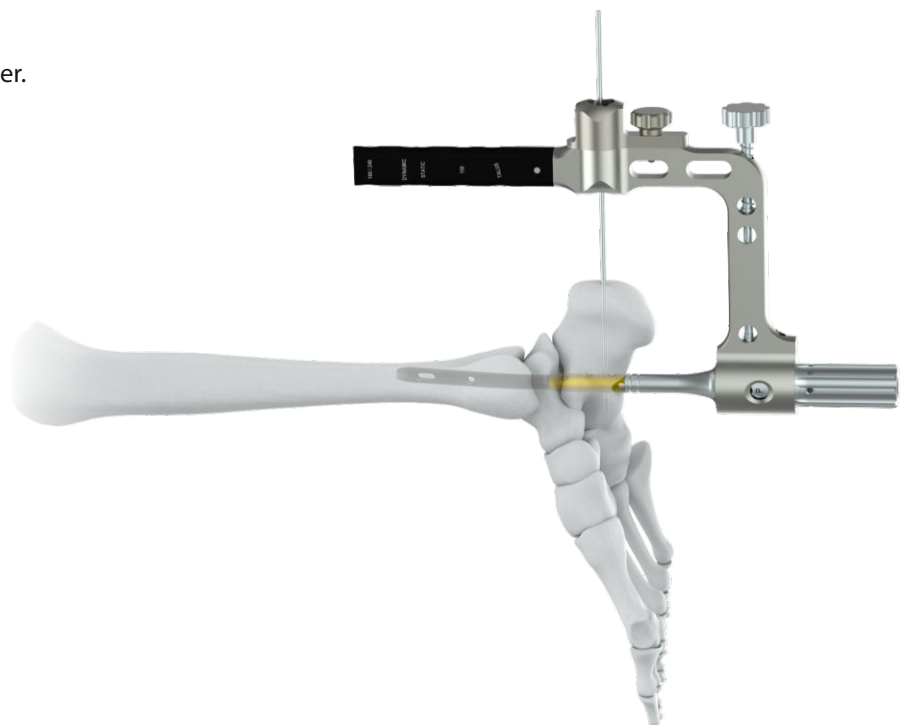

5. Insert spiral blade

Attach the appropriate length spiral blade to the spiral blade inserter using the **(7-066-37)** Connecting Screw.

Pass the spiral blade assembly over the guide wire.

Advance the **(7-066-09)** Spiral Blade Inserter through the aiming arm adapter, ensuring engagement of the inserter's helical grooves with the mating pins of the aiming arm adapter.



Manually advance the spiral blade to the bone. Use light, controlled blows of the slide/fixed hammer in a fixed position to seat the spiral blade. Advancement should be monitored radiographically.

The correct insertion depth is reached when the spiral blade head is flush with the posterior cortex.

Remove the spiral blade connecting screw and spiral blade inserter and adapter.

Remove the 3.2 mm guide wire.

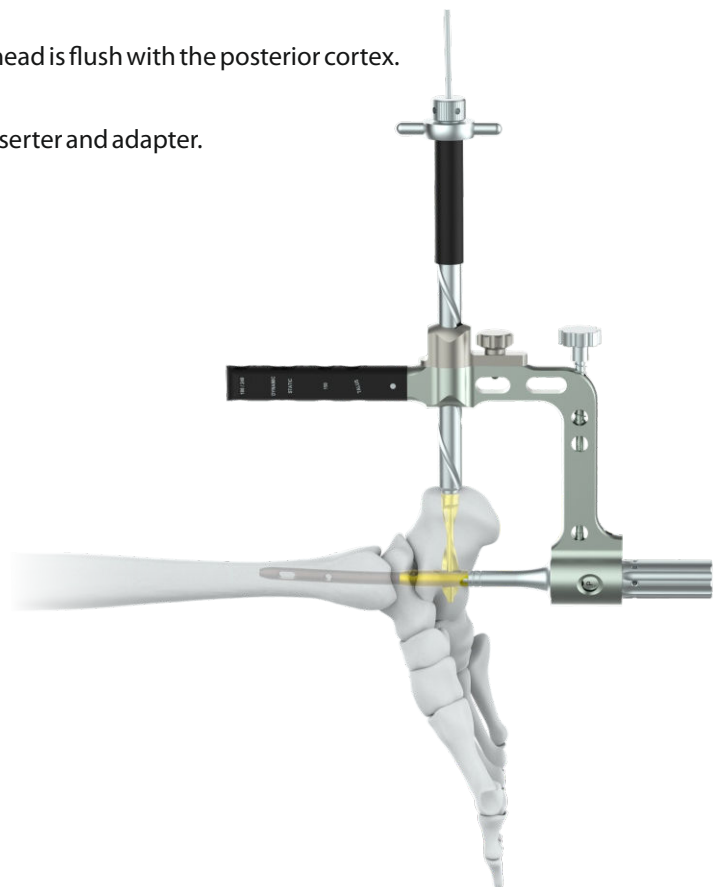

Insert second distal locking screw

6. (optional)

Follow the standard locking procedure with the 12.0 mm/ 8.0 mm protection sleeve, if insertion of a second distal locking element is desired.

Distal Locking With 6.0 mm Locking Screws

1. Confirm nail and screw position

Insert the alignment pin into the aiming arm

Attach the aiming arm to the insertion handle. Orient the aiming arm so the letter "P", for posterior, can be seen on the insertion handle. Tighten the threaded alignment pin.

Insert trocar combination Insert the three part trocar combination **(7-066-13)** 12/8.0mm Protection Sleeve, **(7066-14)** 8.0/3.2mm Drill Sleeve, and **(7-066-17)** Trocar through the most inferior hole of the aiming arm. Make a vertical incision sufficient to retract and protect the skin edges to avoid compromising the wound. Insert the trocar to the bone.

Remove the trocar.

Verify nail insertion depth and location by inserting a 3.2 mm guide wire through the drill sleeve into the bone. Confirm guide wire position radiographically. This position will determine the final position of the most distal locking screw.

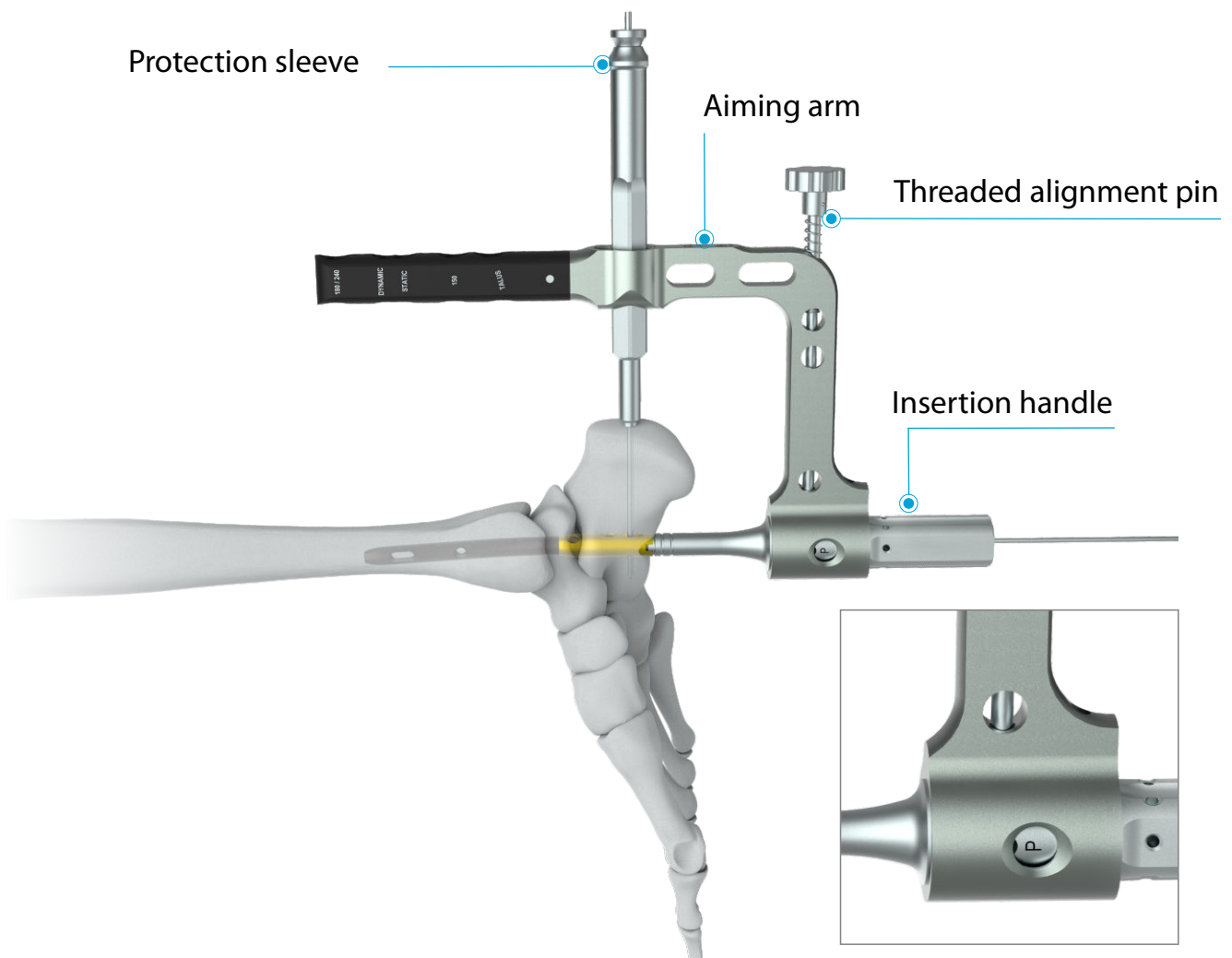

2. Maintain aiming arm in position

Insert a second 3.2 mm guide wire under power through the hole in the aiming arm. This will maintain aiming arm position through the initial locking screw insertion.

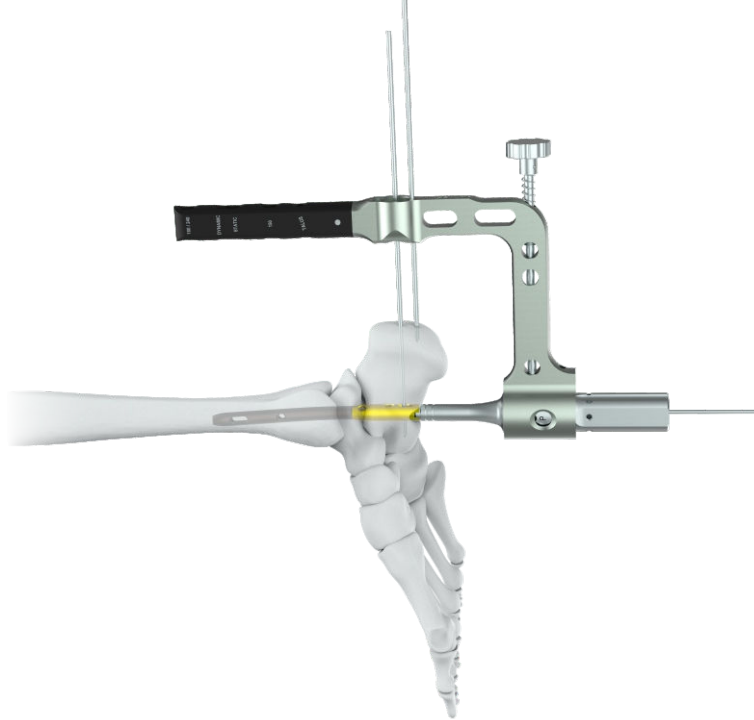

3. Drill and determine locking screw length

Remove the initial 3.2 mm guide wire to allow screw predrilling. Insert the **(7-066-16)** 8.0 mm/5.0 mm drill sleeve into the protection sleeve.

Advance the 5.0 mm drill bit to the subchondral bone of the anterior process of the calcaneus.

Confirm drill bit position radiographically.

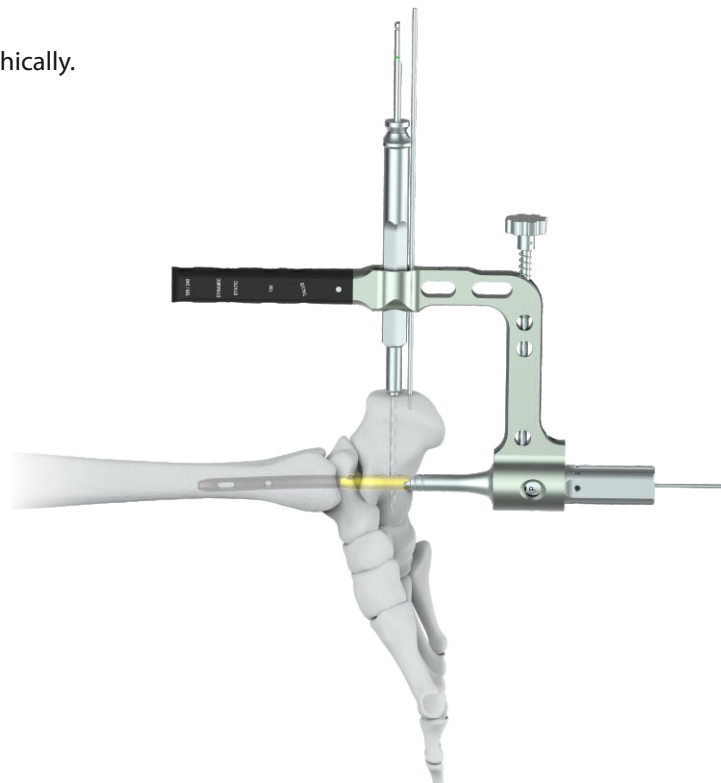

Ensure that the drill sleeve is pressed firmly to the bone and read the locking screw length directly from the drill bit, at the back of the drill sleeve.

Remove the drill bit and drill sleeve.

Disassemble the depth gauge into two parts: the outer sleeve and the measuring device with hook. Insert the measuring device into the protection sleeve.

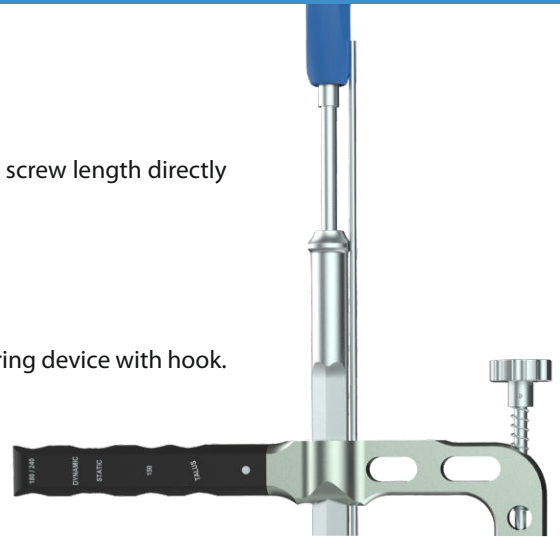

Advance the measuring device to the desired depth, and confirm with imaging. Make sure that the protection sleeve is flush to the bone.

Read the measurement from the back of the protection sleeve, which indicates the appropriate length locking screw.

4. Insert most distal locking screw

Insert the appropriate length 6.0 mm locking screw through the protection sleeve using the **(7-066-26)** Self Retaining Screwdriver, Star Head T25

Verify locking screw length under image intensification.

Remove the 3.2 mm aiming arm stabilization wire.

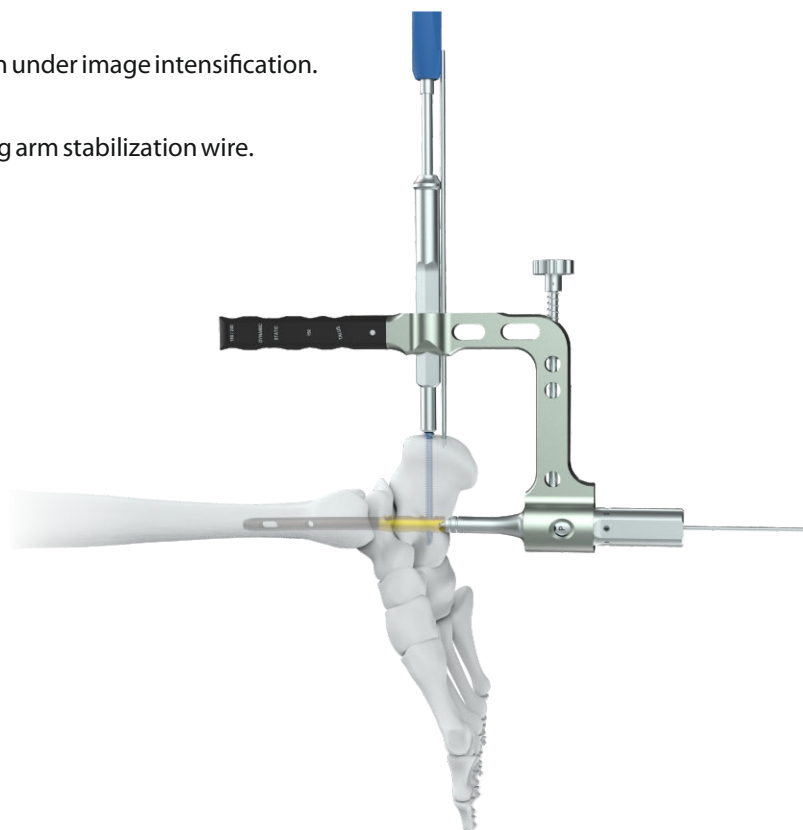

5. Insert second distal locking screw

Repeat the procedure for a second distal locking screw, using the **(7-066-13)** 12.0 mm/8.0 mm protection sleeve.

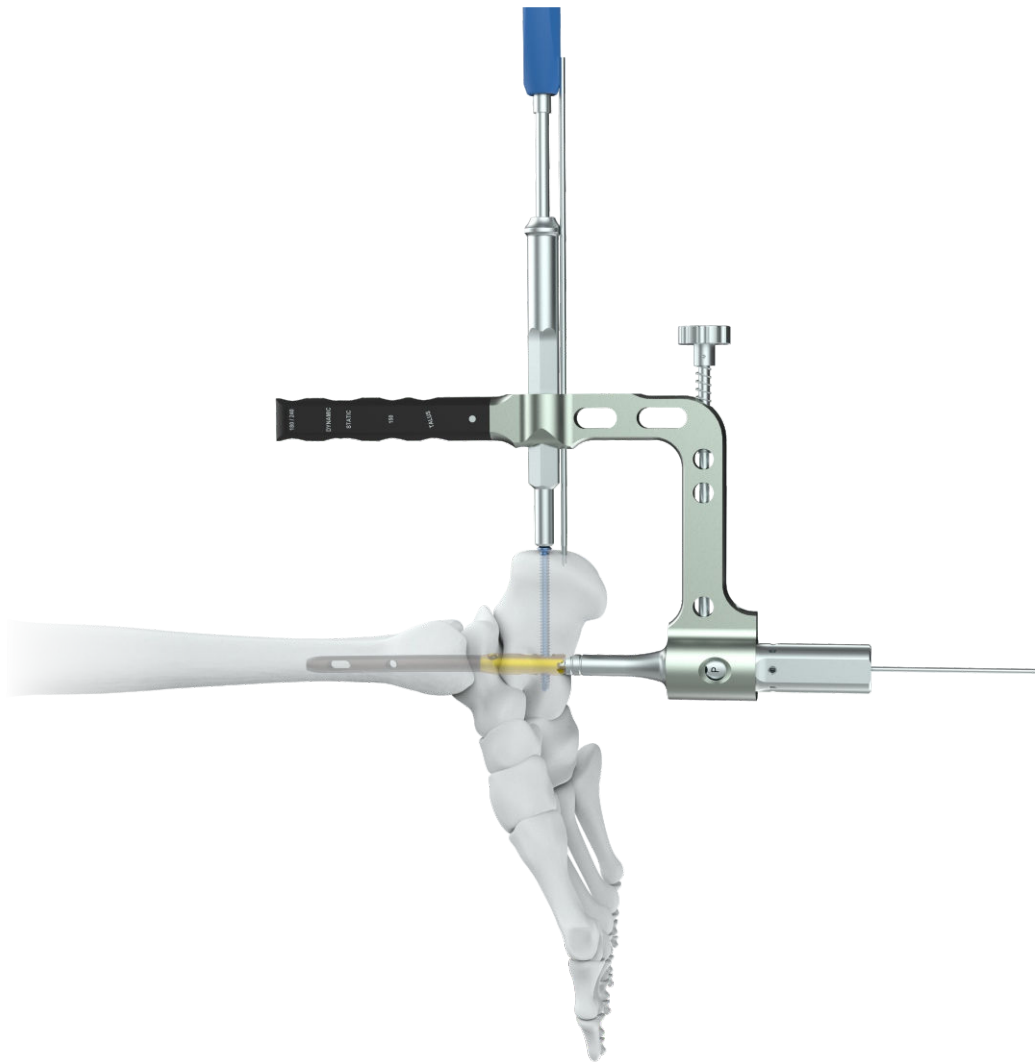

Talus Locking

1. Drill and determine length of talus locking screw

If compression across the subtalar joint is desired, remove the aiming arm by loosening the threaded alignment pin. Thread the driving cap to the insertion handle and use light hammer blows until the gap is sufficiently reduced.

Reattach the aiming arm.

Loosen the threaded alignment pin and rotate the aiming arm laterally so the letter "T", for talus, can be seen on the insertion handle.

Retighten the threaded alignment pin.

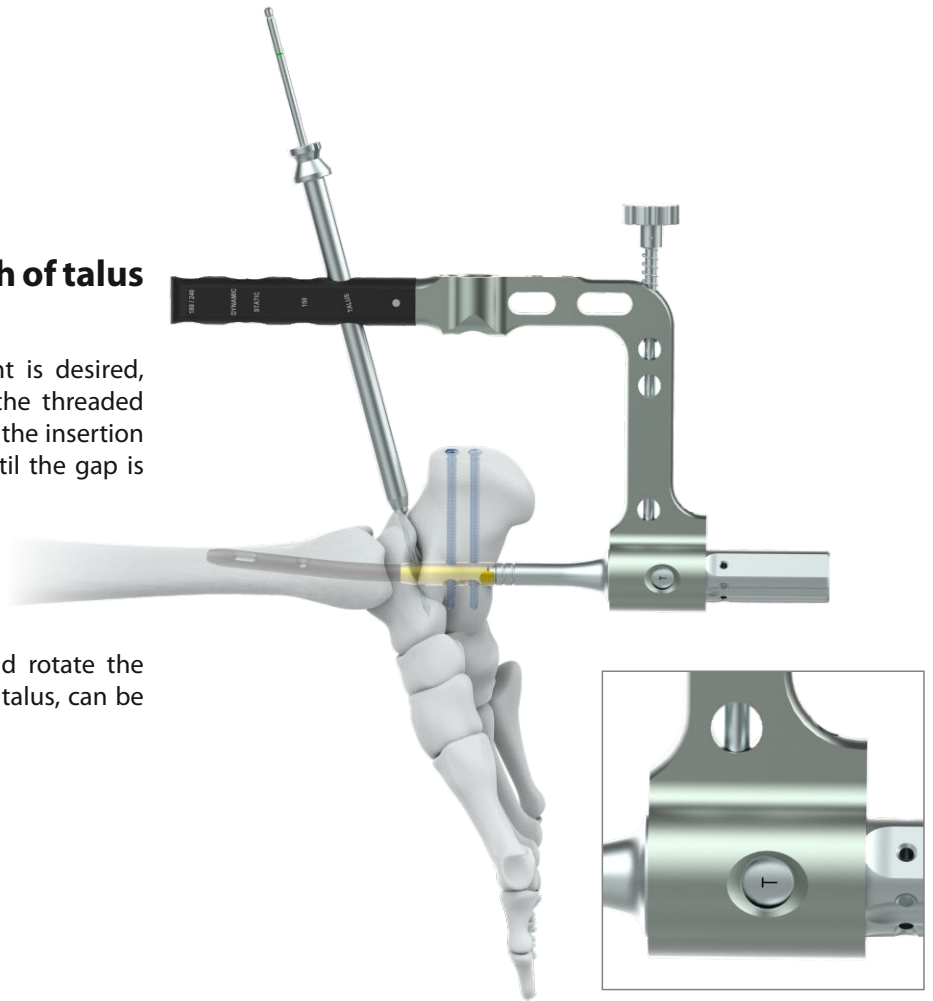

Insert the three-part trocar combination (protection sleeve, drill sleeve, and trocar) into the aiming arm and through a stab incision to the bone. Remove the trocar.

Drill to the anterior side of the talus, using the 4.2 mm drill bit. Confirm drill bit position radiographically. Ensure that the drill sleeve is pressed firmly to the bone and read the locking screw length directly from the drill bit at the back of the drill sleeve.

Remove the drill bit.



1. Drill and determine length of talar locking screw (continued)

After drilling through the talus, remove the drill bit and the drill sleeve.

Disassemble the depth gauge into two parts: the outer sleeve and the measuring device with hook. Insert the measuring device into the protection sleeve. Ensure that the hook grasps the far cortex and the protection sleeve is flush to the bone. Read the measurement from the back of the protection sleeve, which indicates the appropriate length locking screw.

2. Insert talus screw

Insert the appropriate locking screw through the protection sleeve using the Star Drive Screwdriver.

- **Verify locking screw length under image intensification.**

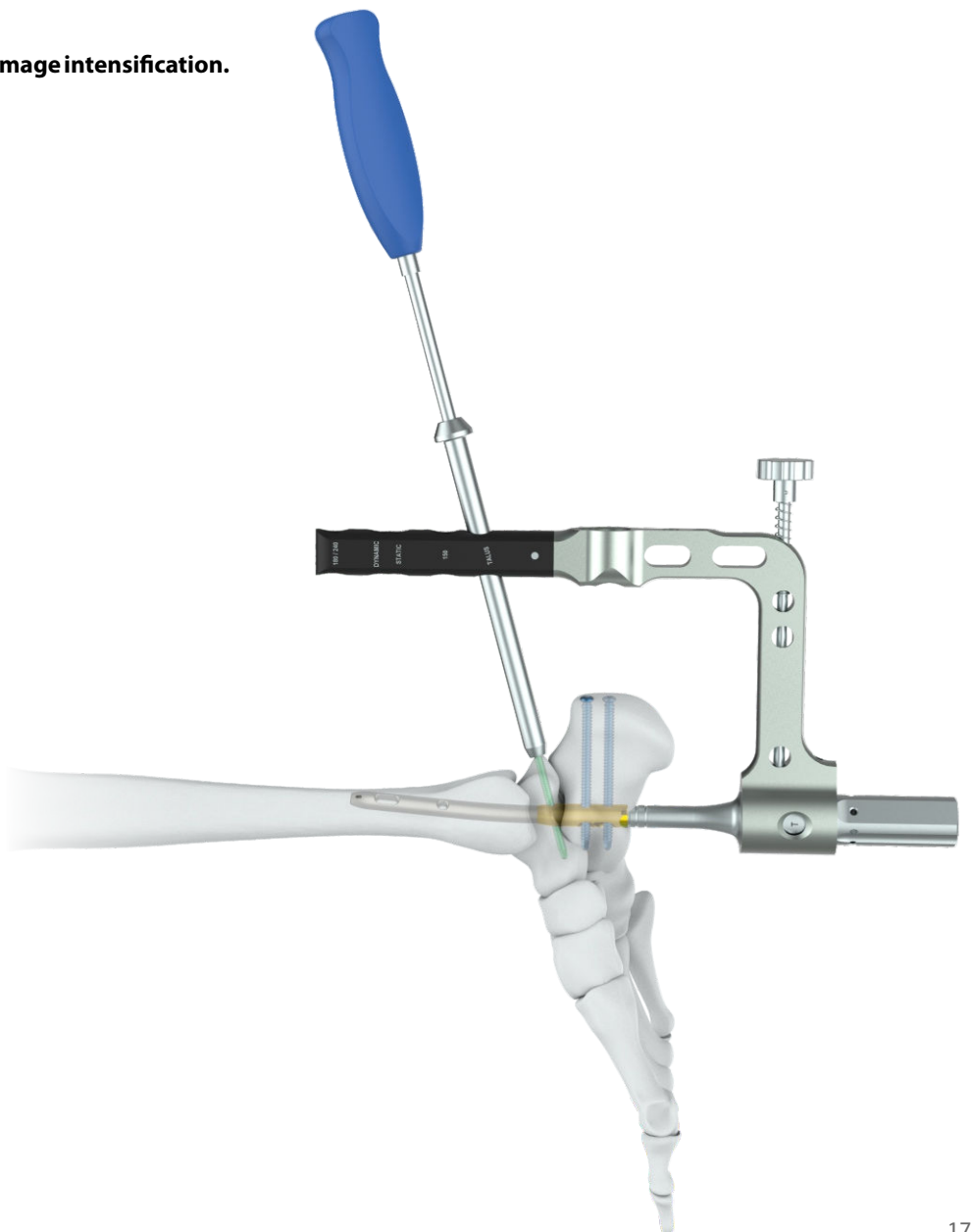

Proximal Locking

1. Drill and determine length of proximal screw

If compression across the ankle joint is desired, remove the aiming arm by loosening the threaded alignment pin. Thread the driving cap into the insertion handle and use light hammer blows until the gap is sufficiently reduced. Reattach the aiming arm and orient it so the letter "M" for medial or "L" for lateral can be seen on the insertion handle.

Tighten the threaded alignment pin.

Choose the screw position (in the static hole or in the dynamic slot). The dynamic slot allows controlled dynamization of the bone fragments.

Insert the protection sleeve, drill sleeve and trocar assembly into the aiming arm and through a stab incision to the bone.

Remove the trocar.

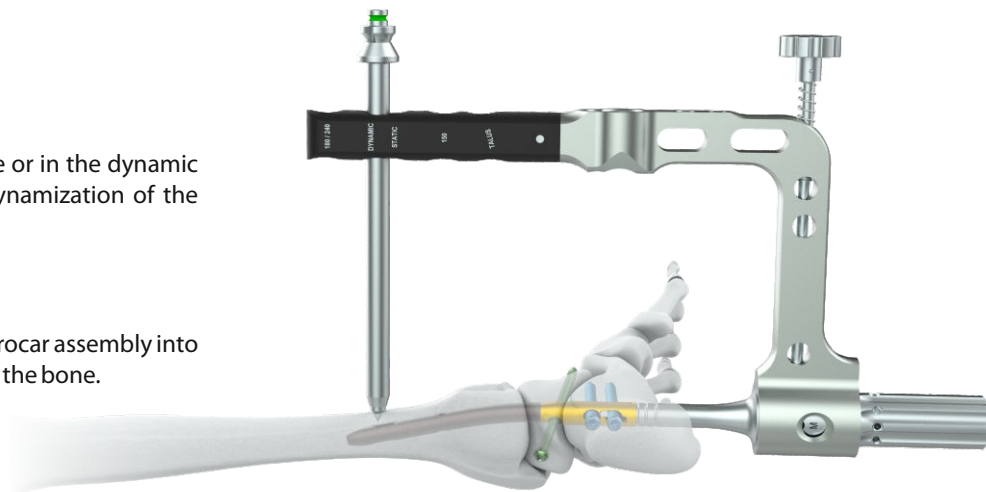

Drill through both cortices using the calibrated drill bit, stopping the drill immediately after penetrating the far cortex. Confirm drill bit position radiographically.

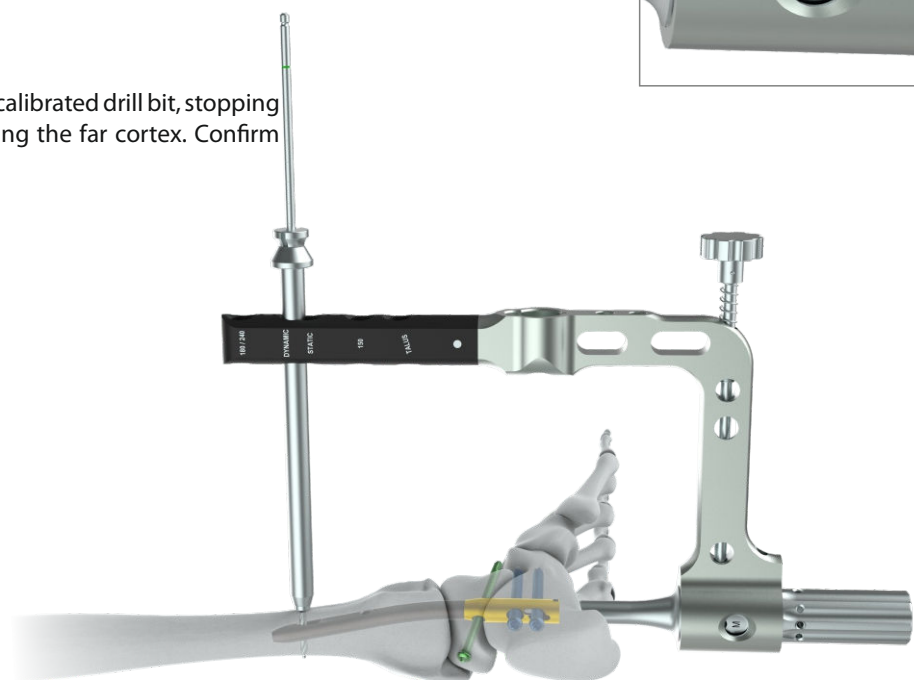

1. Drill and determine length of proximal screw continued

Ensure that the drill sleeve is pressed firmly to the bone and read the locking screw length directly from the drill bit at the back of the drill sleeve.

Remove the drill bit and drill sleeve.

Measure screw length as described above, using the depth gauge.

2. Insert proximal screws

Insert the appropriate locking screw through the protection sleeve using the StarDrive Screwdriver. Verify locking screw length under image intensification.

Repeat the procedure for a second proximal locking screw, if desired.

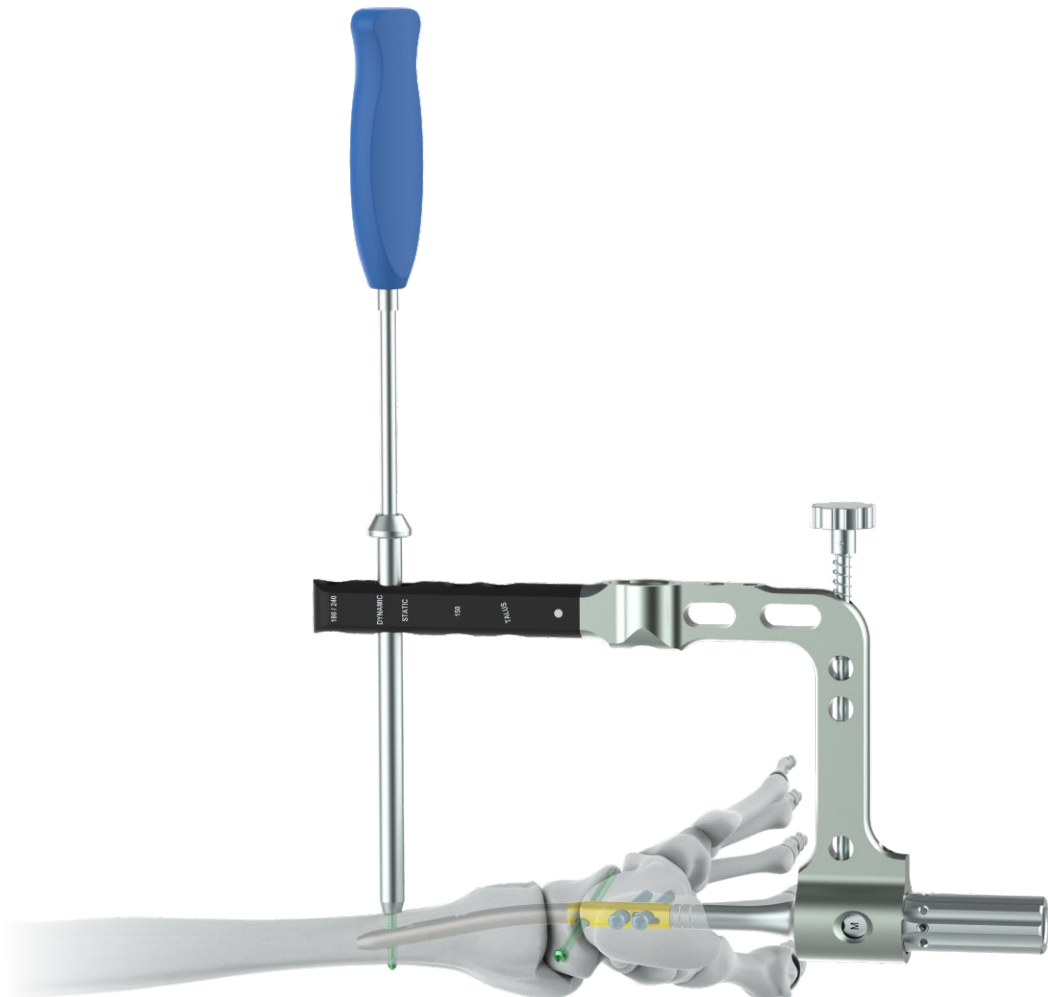

End Cap Insertion

1. Insert end cap

Remove the nail insertion instruments.

For locking screws, insert the Blue end cap with the **(7-066-27)** Self Retaining Screwdriver Shaft, Star Head T25

For a spiral blade, insert the Golden end cap with the **(7-066-27)** Self Retaining Screwdriver Shaft, Star Head T25

Turn the end cap clockwise to thread it into the nail until it engages the distal screw or spiral blade.

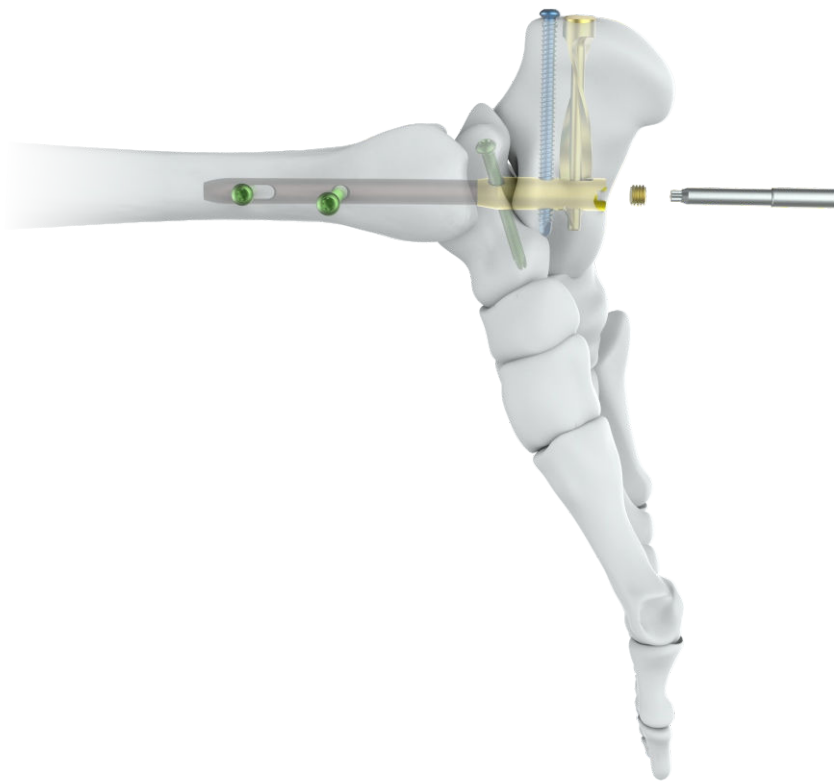
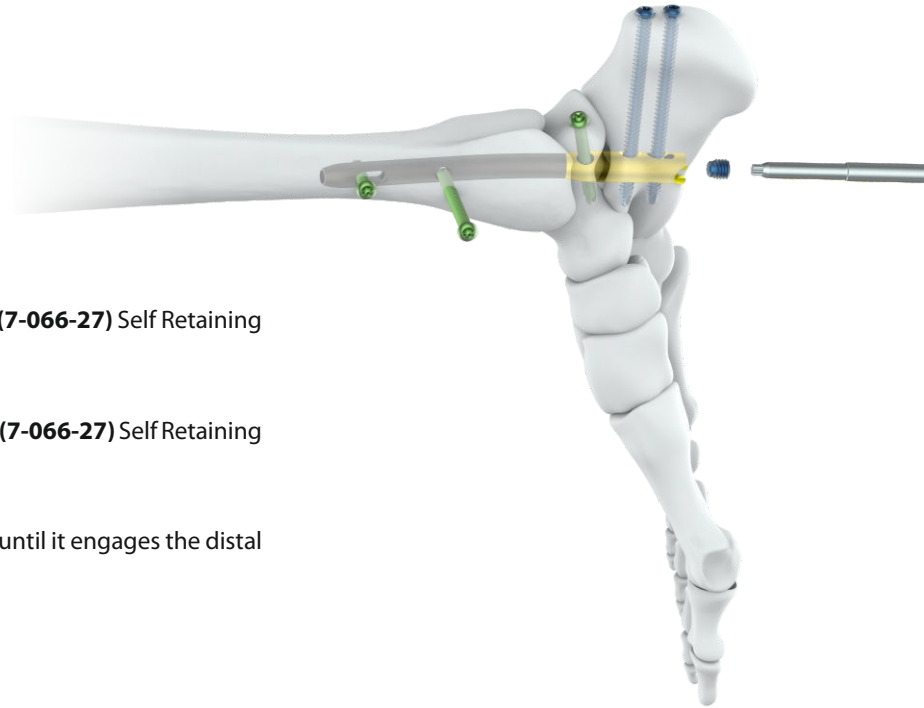

Implant Removal (Optional)

1. Remove end cap

Clear the StarDrive Recesses of the end cap and the locking implants of any tissue ingrowth. Remove the end cap, using

the StarDrive Screwdriver.

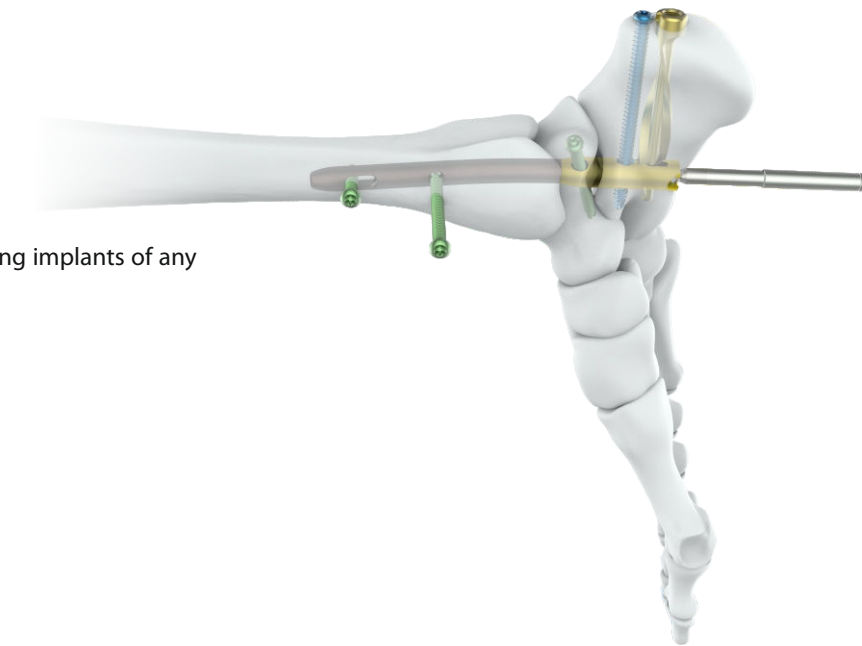

2. Remove spiral blade

Thread the spiral blade extraction screw into the hub of the spiral blade.

Thread the (7-066-36) Hammer Guide into the (7-066-38) Extraction Screw. Use controlled blows of the (7-066-11) Sliding Hammer to extract the spiral blade.

Leave a loose grip on the extraction assembly, as it and the blade rotate during extraction.

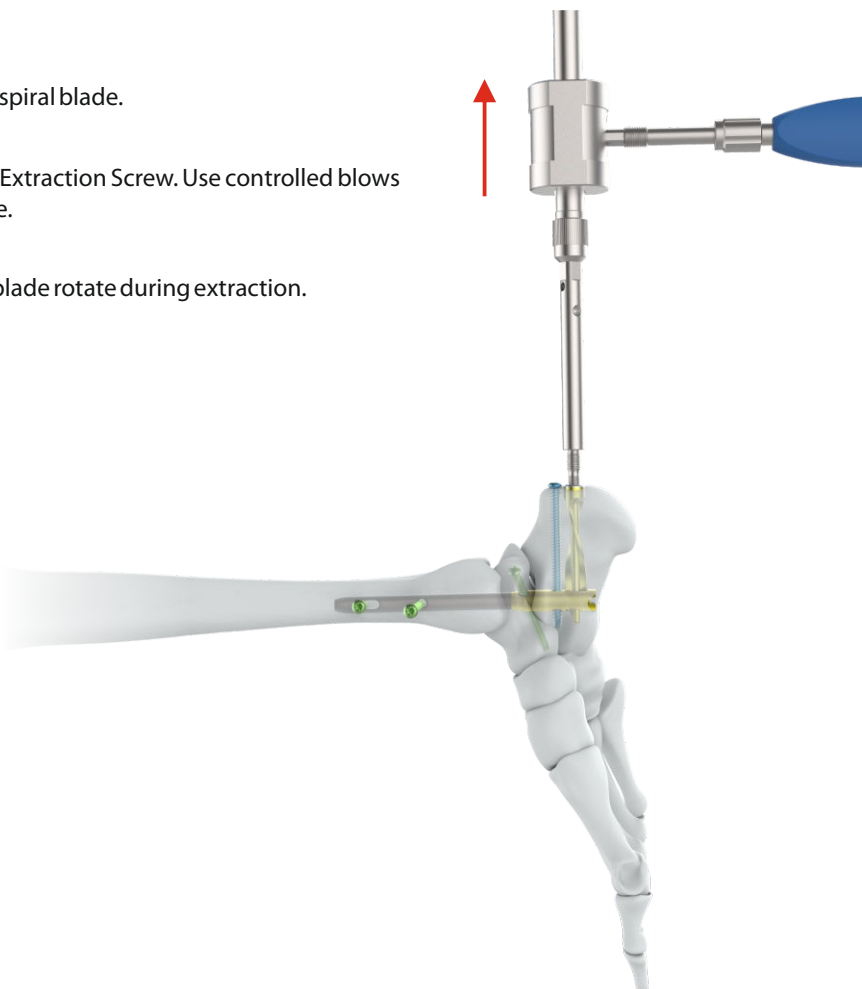

3. Remove locking screws

Remove all but the most proximal locking screw.

Attach the extraction screw to the nail.

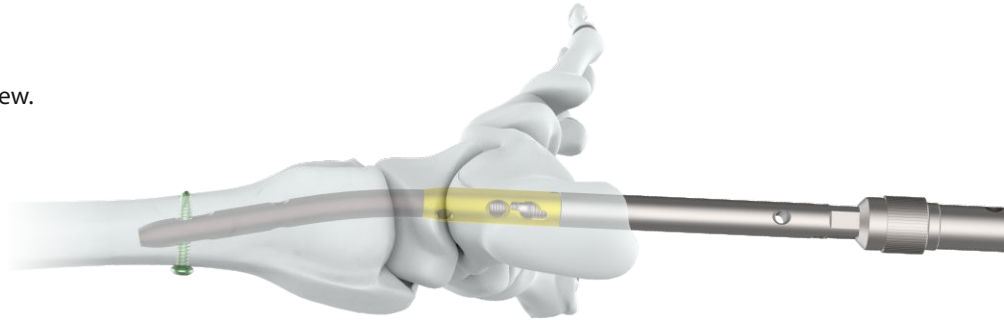

4. Remove nail

Attach the hammer guide to the extraction screw.

Remove the last locking screw.

Remove the nail by applying gentle blows with the hammer.

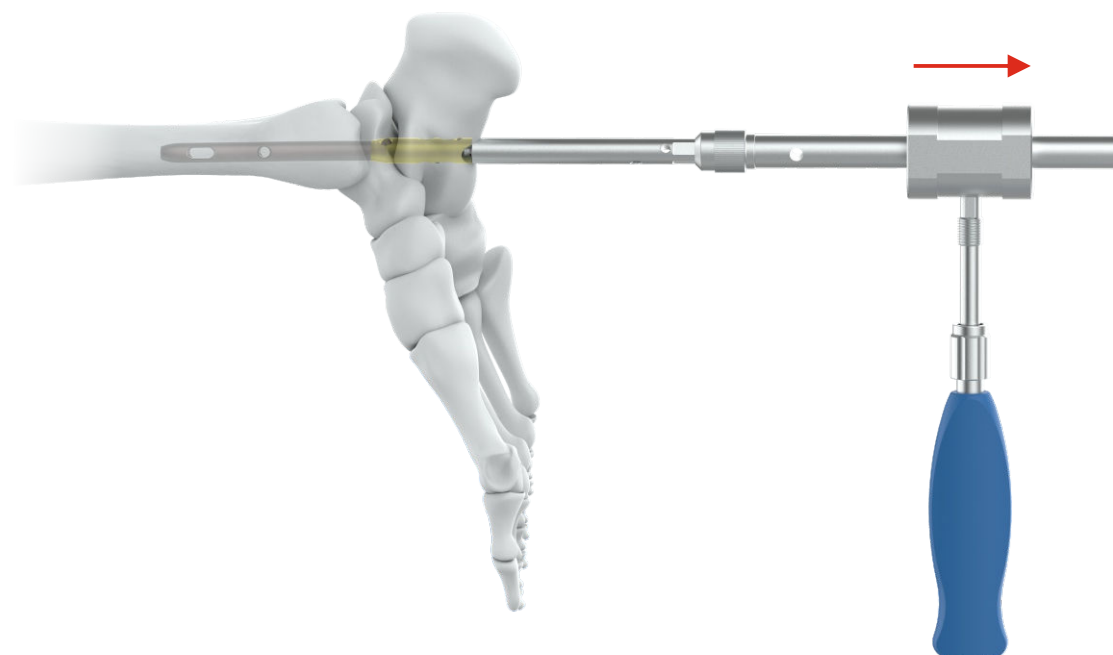

Tarsus Nail

Ø Dia	Length (mm)	Titanium (Left)	Titanium (Right)
10mm	150mm	1-005-150LTI	1-005-150RTI
10mm	180mm	1-005-180LTI	1-005-180RTI
10mm	240mm	1-005-240LTI	1-005-240RTI
12mm	150mm	1-006-150LTI	1-006-150RTI
12mm	180mm	1-006-180LTI	1-006-180RTI
12mm	240mm	1-006-240LTI	1-006-240RTI
13mm	150mm	1-007-150LTI	1-007-150RTI
13mm	180mm	1-007-180LTI	1-007-180RTI
13mm	240mm	1-007-240LTI	1-007-240RTI



Left

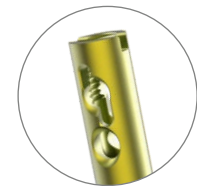

Right

5.0mm Locking Bolt, (Star Head)

Ø Dia	Length (mm)	Titanium
5.0mm	26	1-008-026TI
5.0mm	28	1-008-028TI
5.0mm	30	1-008-030TI
5.0mm	32	1-008-032TI
5.0mm	34	1-008-034TI
5.0mm	36	1-008-036TI
5.0mm	38	1-008-038TI
5.0mm	40	1-008-040TI
5.0mm	42	1-008-042TI
5.0mm	44	1-008-044TI
5.0mm	46	1-008-046TI
5.0mm	48	1-008-048TI
5.0mm	50	1-008-050TI
5.0mm	52	1-008-052TI
5.0mm	54	1-008-054TI
5.0mm	56	1-008-056TI
5.0mm	58	1-008-058TI
5.0mm	60	1-008-060TI
5.0mm	62	1-008-062TI
5.0mm	64	1-008-064TI
5.0mm	66	1-008-066TI
5.0mm	68	1-008-068TI
5.0mm	70	1-008-070TI
5.0mm	72	1-008-072TI
5.0mm	74	1-008-074TI
5.0mm	76	1-008-076TI
5.0mm	78	1-008-078TI
5.0mm	80	1-008-080TI
5.0mm	85	1-008-085TI
5.0mm	90	1-008-090TI
5.0mm	95	1-008-095TI
5.0mm	100	1-008-100TI



6.0mm Locking Bolt, (Star Head)

Ø Dia	Length (mm)	Titanium
6.0mm	26	1-009-026TI
6.0mm	28	1-009-028TI
6.0mm	30	1-009-030TI
6.0mm	32	1-009-032TI
6.0mm	34	1-009-034TI
6.0mm	36	1-009-036TI
6.0mm	38	1-009-038TI
6.0mm	40	1-009-040TI
6.0mm	42	1-009-042TI
6.0mm	44	1-009-044TI
6.0mm	46	1-009-046TI
6.0mm	48	1-009-048TI
6.0mm	50	1-009-050TI
6.0mm	52	1-009-052TI
6.0mm	54	1-009-054TI
6.0mm	56	1-009-056TI
6.0mm	58	1-009-058TI
6.0mm	60	1-009-060TI
6.0mm	64	1-009-064TI
6.0mm	68	1-009-068TI
6.0mm	72	1-009-072TI
6.0mm	76	1-009-076TI
6.0mm	80	1-009-080TI
6.0mm	85	1-009-085TI
6.0mm	90	1-009-090TI
6.0mm	95	1-009-095TI
6.0mm	100	1-009-100TI
6.0mm	105	1-009-105TI
6.0mm	110	1-009-110TI
6.0mm	115	1-009-115TI
6.0mm	120	1-009-120TI
6.0mm	125	1-009-125TI



Spiral Blade

Length (mm)	Titanium
45	1-010-045TI
50	1-010-050TI
55	1-010-055TI
60	1-010-060TI
65	1-010-065TI
70	1-010-070TI
75	1-010-075TI
80	1-010-080TI
85	1-010-085TI
90	1-010-090TI
95	1-010-095TI
100	1-010-100TI



Tarsus Nail End Cap, for Securing Spiral Blade, Titanium

Titanium

1-011-01TI



Tarsus Nail End Cap, for Securing the most distal Locking Bolt, Titanium

Titanium

1-011-02TI



7-066-01 Radiographic Ruler for Tarsus Nail



7-066-02 18/8.0mm Protection Sleeve for Tarsus Nail



7-066-03 Threaded Alignment Pin for Tarsus Nail



7-066-04 Driving Cap for Tarsus Nail



7-066-05 Insertion Handle for Tarsus Nail



7-066-06 Ø5.0mm Three Fluted Drill Bit with Quick Couling End for Tarsus Nail



7-066-07 Aiming Arm for Tarsus Nail



7-066-08 Aiming Arm Adapter with Bolt for Tarsus Nail

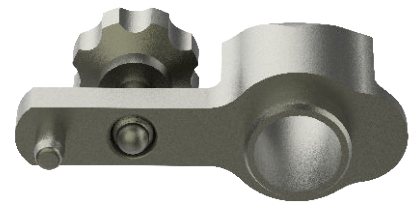

7-066-09 Spiral Blade Inserter for Tarsus Nail



7-066-10 Holding Device for Guide Wire for Tarsus Nail

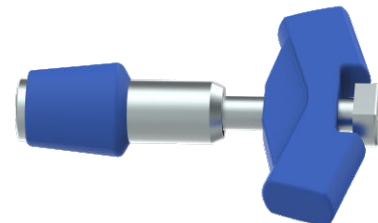

7-066-11 Sliding Hammer for Tarsus Nail

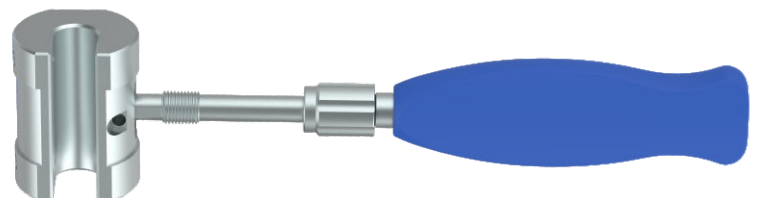

7-066-12 Ø4.2mm Three Fluted Drill Bit with Quick Couling End for Tarsus Nail



7-066-13 12/8.0mm Protection Sleeve for Tarsus Nail



7-066-14 8.0/3.2mm Drill Sleeve for Tarsus Nail



7-066-15 8.0/4.2mm Drill Sleeve for Tarsus Nail



7-066-16 8.0/5.0mm Drill Sleeve for Tarsus Nail



7-066-17 3.2mm Trocar for Tarsus Nail



7-066-18 4.2mm Trocar for Tarsus Nail



7-066-19 5.0mm Trocar for Tarsus Nail



7-066-20 Depth Gauge measuring upto 100mm for Tarsus Nail



7-066-21 15.0/13.0mm Protection Sleeve for Tarsus Nail



7-066-22 13.0/3.2mm Guide Wire Sleeve for Tarsus Nail



7-066-23 Measuring Device for Spiral Blade for Tarsus Nail



7-066-24 Universal Screwdriver, Hex 8mm for Tarsus Nail



7-066-25 Guide Wire Push Rod for Tarsus Nail



7-066-26 Self Retaining Screwdriver, Star Head T25 for Tarsus Nail



7-066-27 Self Retaining Screwdriver Shaft, Star Head T25 for Tarsus Nail



7-066-28 Screw Holding Sleeve with Locking Device for Tarsus Nail



7-066-29 3.2mm Threaded Guide Wire, Length 290mm for Tarsus Nail



7-066-30 Cannulated Nail Connecting Screw for Insertion Handle for Tarsus Nail



7-066-31 4.5mm Pin Wrench for Tarsus Nail



7-066-32 Ratchet Wrench, Hex 11mm for Tarsus Nail



7-066-33 13.0mm Cannulated Entry Reamer for Tarsus Nail



7-066-34 13.0mm Protection Sleeve for Tarsus Nail

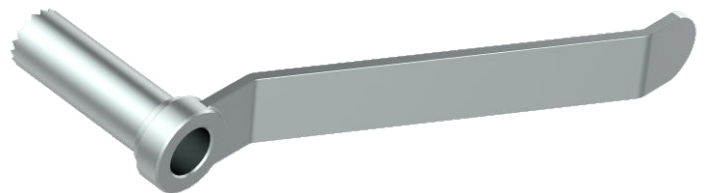

7-066-35 13.0/3.2mm Trocar for Tarsus Nail



7-066-36 Hammer Guide for Tarsus Nail



7-066-37 Connecting Screw for Spiral Blade Inserter for Tarsus Nail



7-066-38 Extraction Screw for Tarsus Nail



7-066-39 Cannulated Shaft, Hex 8mm for Tarsus Nail



7-066-40 3.2mm Threaded Guide Wire, Length 400mm for Tarsus Nail

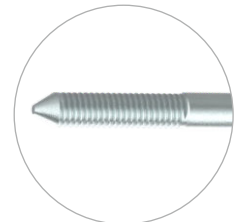

7-066-41 Container for Tarsus Nailing Instrument Set



7-066 Tarsus Nailing Instrument Set

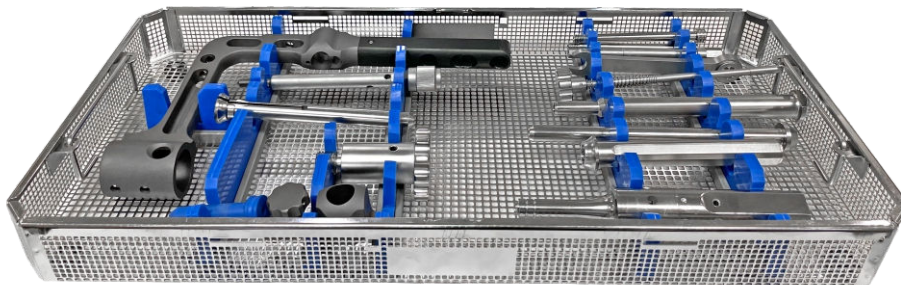
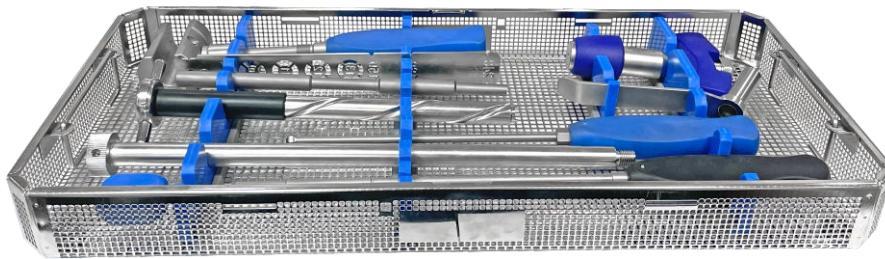
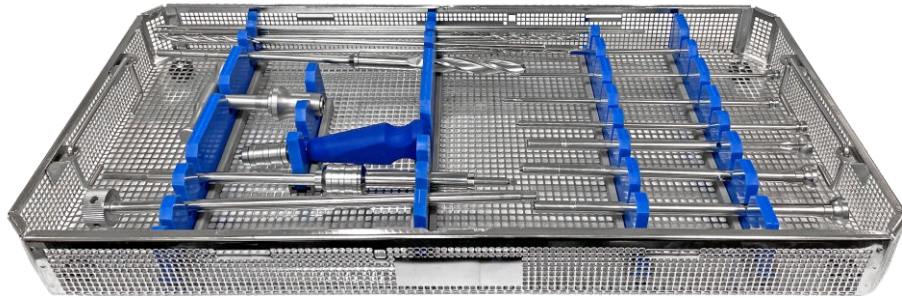

7-066 Tarsus Nailing Instrument Set

Code	Set Consisting of	Qty.
7-066-01	Radiographic Ruler for Tarsus Nail	1
7-066-02	18/8.0mm Protection Sleeve for Tarsus Nail	1
7-066-03	Threaded Alignment Pin for Tarsus Nail	1
7-066-04	Driving Cap for Tarsus Nail	1
7-066-05	Insertion Handle for Tarsus Nail	1
7-066-06	Ø5.0mm Three Fluted Drill Bit with Quick Couling End for Tarsus Nail	1
7-066-07	Aiming Arm for Tarsus Nail	1
7-066-08	Aiming Arm Adapter with Bolt for Tarsus Nail	1
7-066-09	Spiral Blade Inserter for Tarsus Nail	1
7-066-10	Holding Device for Guide Wire for Tarsus Nail	1
7-066-11	Sliding Hammer for Tarsus Nail	1
7-066-12	Ø4.2mm Three Fluted Drill Bit with Quick Couling End for Tarsus Nail	1
7-066-13	12/8.0mm Protection Sleeve for Tarsus Nail	1
7-066-14	8.0/3.2mm Drill Sleeve for Tarsus Nail	1
7-066-15	8.0/4.2mm Drill Sleeve for Tarsus Nail	1
7-066-16	8.0/5.0mm Drill Sleeve for Tarsus Nail	1
7-066-17	3.2mm Trocar for Tarsus Nail	1
7-066-18	4.2mm Trocar for Tarsus Nail	1
7-066-19	5.0mm Trocar for Tarsus Nail	1
7-066-20	Depth Gauge measuring upto 100mm for Tarsus Nail	1
7-066-21	15.0/13.0mm Protection Sleeve for Tarsus Nail	1
7-066-22	13.0/3.2mm Guide Wire Sleeve for Tarsus Nail	1
7-066-23	Measuring Device for Spiral Blade for Tarsus Nail	1
7-066-24	Universal Screwdriver, Hex 8mm for Tarsus Nail	1
7-066-25	Guide Wire Push Rod for Tarsus Nail	1
7-066-26	Self Retaining Screwdriver, Star Head T25 for Tarsus Nail	1
7-066-27	Self Retaining Screwdriver Shaft, Star Head T25 for Tarsus Nail	1
7-066-28	Screw Holding Sleeve with Locking Device for Tarsus Nail	1
7-066-29	3.2mm Threaded Guide Wire, Length 290mm for Tarsus Nail	1
7-066-30	Cannulated Nail Connecting Screw for Insertion Handle for Tarsus Nail	1
7-066-31	4.5mm Pin Wrench for Tarsus Nail	1
7-066-32	Ratchet Wrench, Hex 11mm for Tarsus Nail	1
7-066-33	13.0mm Cannulated Entry Reamer for Tarsus Nail	1
7-066-34	13.0mm Protection Sleeve for Tarsus Nail	1
7-066-35	13.0/3.2mm Trocar for Tarsus Nail	1
7-066-36	Hammer Guide for Tarsus Nail	1
7-066-37	Connecting Screw for Spiral Blade Inserter for Tarsus Nail	1
7-066-38	Extraction Screw for Tarsus Nail	1
7-066-39	Cannulated Shaft, Hex 8mm for Tarsus Nail	1
7-066-40	3.2mm Threaded Guide Wire, Length 400mm for Tarsus Nail	1
7-066-41	Container for Tarsus Nailing Instrument Set	1

7-006 Flexible Reamer Instrument set

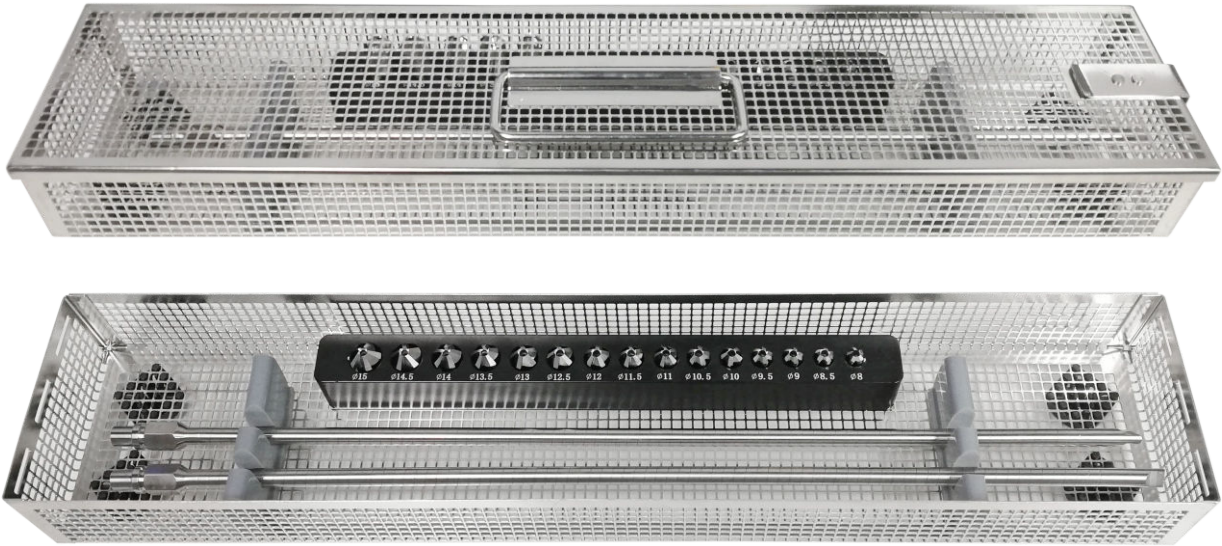

1459-006 Flexible Reamer Shaft (AO Connection)

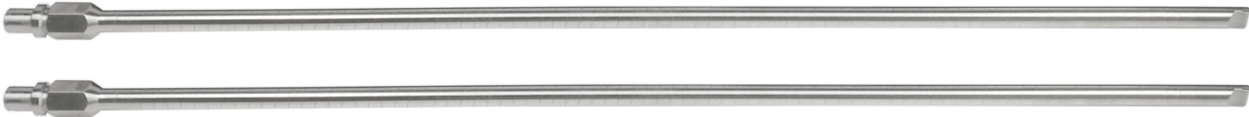

Reamer Head

Code	Dia	Code	Dia
7-006-01	Ø8mm	1459-015	Ø12mm
1459-008	Ø8.5mm	1459-016	Ø12.5mm
1459-009	Ø9mm	1459-017	Ø13mm
1459-010	Ø9.5mm	1459-018	Ø13.5mm
1459-011	Ø10mm	1459-019	Ø14mm
1459-012	Ø10.5mm	7-006-02	Ø14.5mm
1459-013	Ø11mm	7-006-03	Ø15mm
1459-014	Ø11.5mm		





USA

Auxein Inc.
1500 Nw 89th Court, Suite 107-108
Doral, Florida 33172
Tel: +1 305 395 6062
E Fax: +1 305 395 6262
Email: USoffice@auxein.com

MEXICO

Auxein México, S.A. de C.V.
Tepic 139 int 801, Colonia Roma Sur,
Alcaldía Cuauhtémoc, CDMX,
México, C.P. 06760
Tel: +521 55 7261 0318
Email: info@auxein.mx

INDIA

Auxein Medical Pvt. Ltd.
Plot No. 168-169-170, Phase-4,
Kundli Industrial Area,
HSIIDC, Sector-57, Sonapat - 131028, Haryana
Tel: +91 99106 43638 | Fax: +91 86077 70197
Email: info@auxein.com